

## Block Diagram for a Radio Design Solution for a Satellite ISP Application

*Presents a block diagram for a satellite ISP. Uses the MAX2114 direct conversion tuner IC which has an on-chip local oscillator (LO), 10.8dB noise figure, and supports an RF input range of -25dBm to -68dBm. The MAX2721 direct I/Q modulator provides a VGA with 35dB control range. 35dBc of sideband suppression and 30dBc carrier suppression are achieved.*

### Overview

Satellite is a growing alternative for Internet connections. Traditional, wired, broadband Internet access methods such as xDSL, cable, T1, and ISDN provide high-speed Internet access; however, a satellite Internet connection, also affording high-speed Internet access, is less expensive to install and easier to expand.

A satellite Internet connection transceiver requires a broadband, high-linearity, and low-noise system to ensure a high-quality signal for baseband processing. Maxim's advanced, direct, up-and-down conversion chipset delivers the complete solution for this application, with its excellent performance, low cost, and small size. The following block diagram shows a typical application.

### The MAX2114: A Direct-Conversion Tuner IC

The MAX2114 is the industry's latest and most advanced satellite tuner IC. It includes a low-noise amplifier (LNA) with gain control, I/Q downconverting mixers, integrated lowpass filters with baseband gain and frequency control, and modulus 1/2 and modulus 32/33 prescalers. The MAX2114 has an on-chip local oscillator (LO), requiring only an external varactor-tuned LC tank for operation. Furthermore, an integrated LO doubler enables the MAX2114 to tune the frequency more than an octave on the single LC tank. The device delivers a 10.8dB noise figure and a +8dBm input IP3. The wide gain-control range of the device supports an RF input range from -25dBm to -68dBm per carrier. The integrated 7th-order lowpass filter relaxes baseband sampling-rate requirements and improves the carrier-to-noise ratio (C/N). The device uses direct downconversion architecture, thereby eliminating the costly image rejection SAW filter or ceramic filter to reduce the implementation size of the receiver. The MAX2114 is offered in a 44-pin QFN package with an exposed paddle.

### The MAX2721: A Direct I/Q Modulator with a VGA and a PA Driver

The MAX2721 is a low-cost, high-performance, direct I/Q modulator designed for broadband wireless communication. The device includes an I/Q modulator, a variable-gain amplifier (VGA), and a driver for the power amplifier. The quadrature modulator accepts differential baseband I/Q signals and directly modulates the RF carrier in the 2.1GHz to 2.5GHz range. The VGA provides a 35dB range of output power control. The modulator's amplitude and phase balance yields 35dBc of sideband suppression and 30dBc of carrier suppression. The device features an LO frequency doubler that allows the external LO source to operate at half frequency to minimize RF-LO leakage and reduce DC offset in direct downconversion architecture.

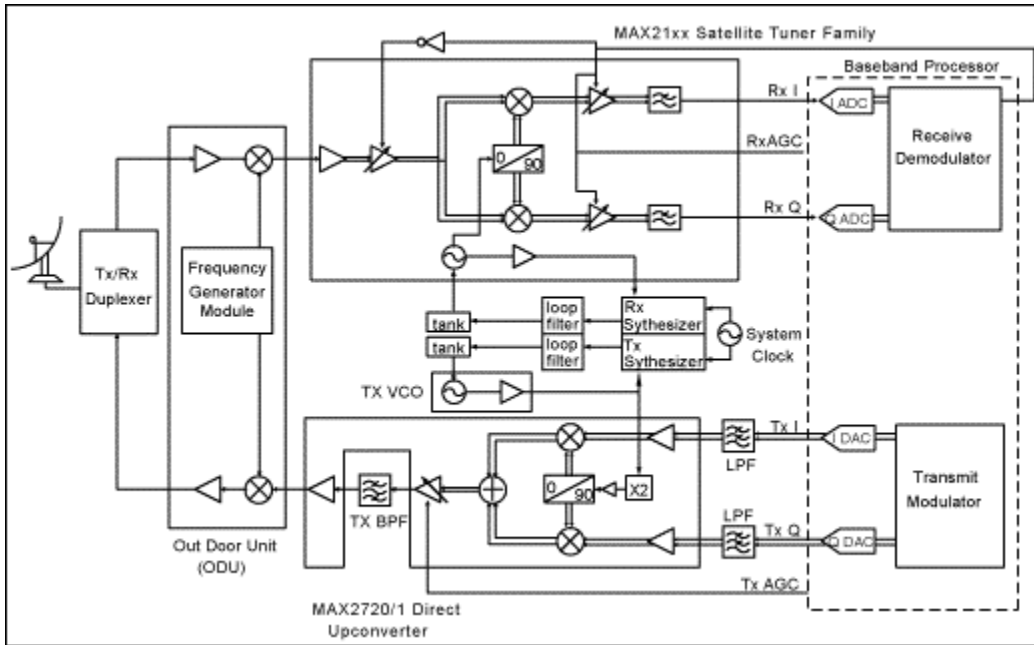

Satellite ISP: satellite Internet connection application

May 2001

**MORE INFORMATION**

MAX2114: [QuickView](#)  
 MAX2721: [QuickView](#)

-- [Full \(PDF\) Data Sheet \(120k\)](#)  
 -- [Full \(PDF\) Data Sheet \(328k\)](#)

-- [Free Sample](#)  
 -- [Free Sample](#)